

Lil' Ripper

Designed by: Shaun Frank

www.3DMONDESIGNS.com

Plans are for personal use only.

6mm and 3mm foam and 1/16" plywood used

Wingspan: 31"

Length: 31.5"



A cross-sectional diagram of a motor mount assembly. The top part is a trapezoidal shape representing a foam layer, with the text "6mm foam" centered inside. Below this is a thin horizontal rectangular bar representing a carbon tube, with the text ".120\" x 5\" Carbon tube" centered above it. At the bottom is a trapezoidal shape representing a motor mount, with the text "6mm Foam doubler Motor mount" centered inside. The entire assembly is shown within a larger, wider trapezoidal outline that tapers towards the top and bottom edges.

6mm foam

.120" x 5" Carbon tube

**6mm
Foam doubler
Motor mount**

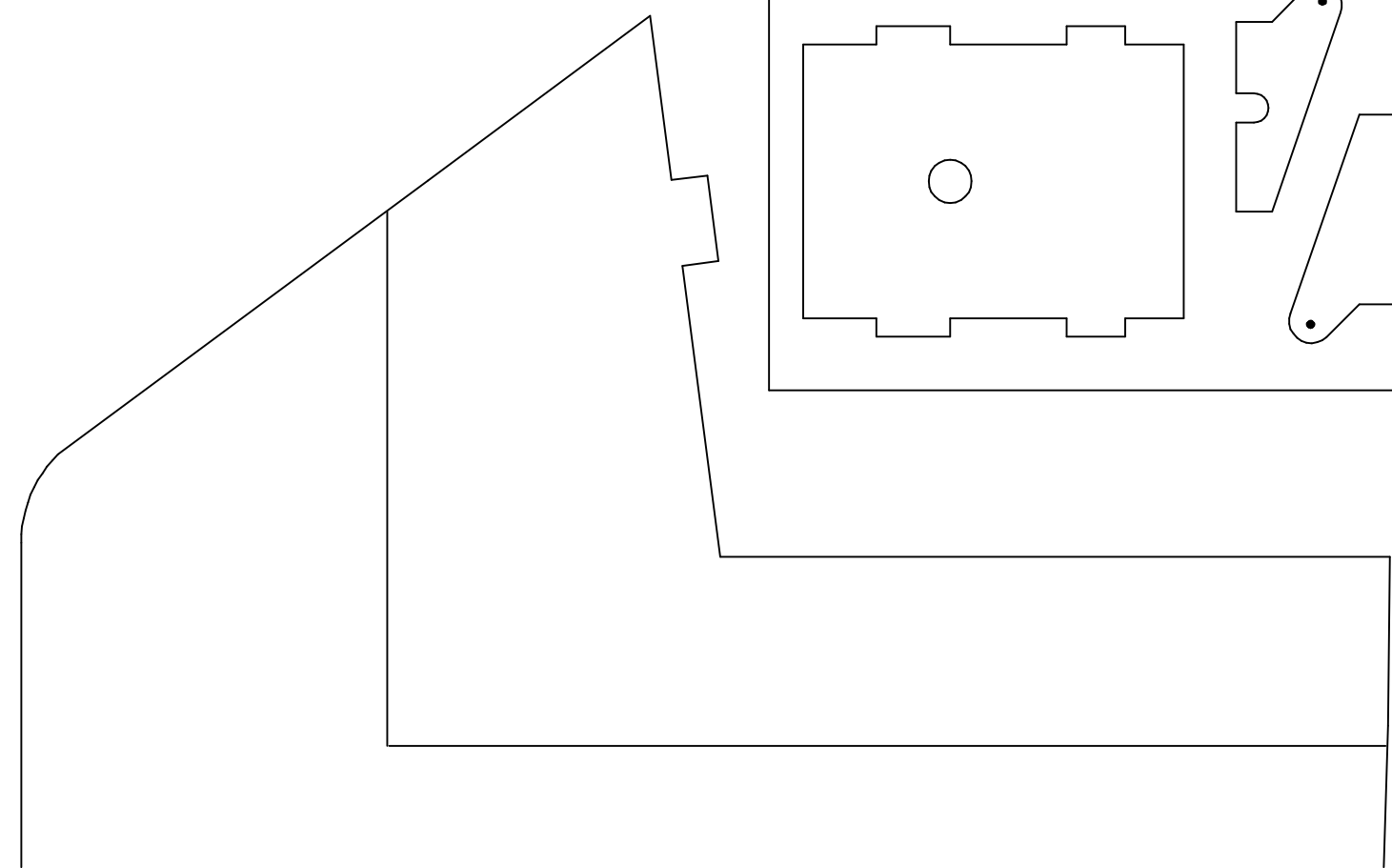

1/16" Plywood pieces

A collection of six small plywood pieces. At the top are two identical trapezoidal pieces, each with a small circular hole near the top-left corner. Below them is a larger rectangular piece with a central circular hole and notches on its top and bottom edges. To the right of this larger piece are three smaller, irregular pieces, each with a small circular hole.

Flying Weight: 9-11 oz's

Motor: 24g 1300-1500kv "Blue Wonder"

Speed Control: 10-15 amp

Battery: 3s 500-800 mah

Servos: Hitec HS-55 or similar

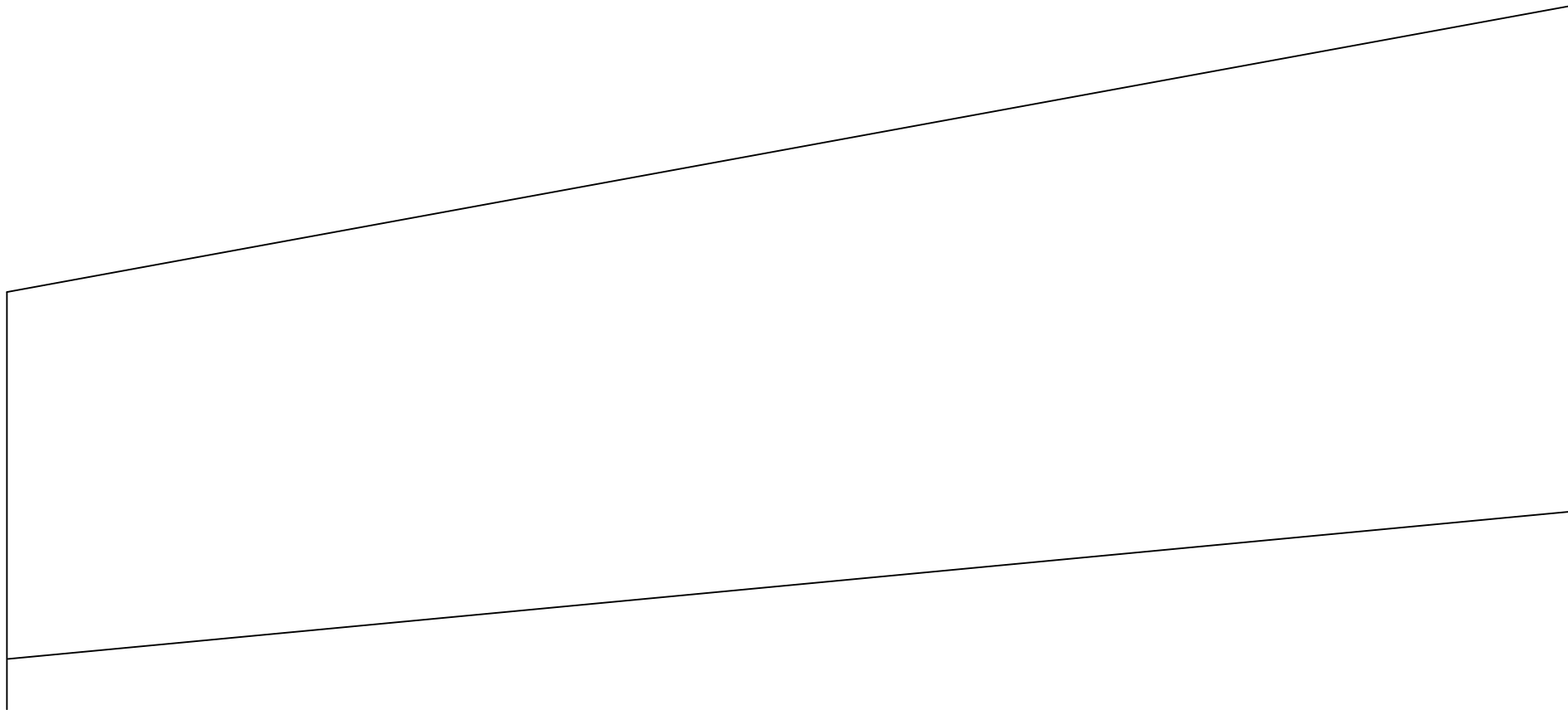

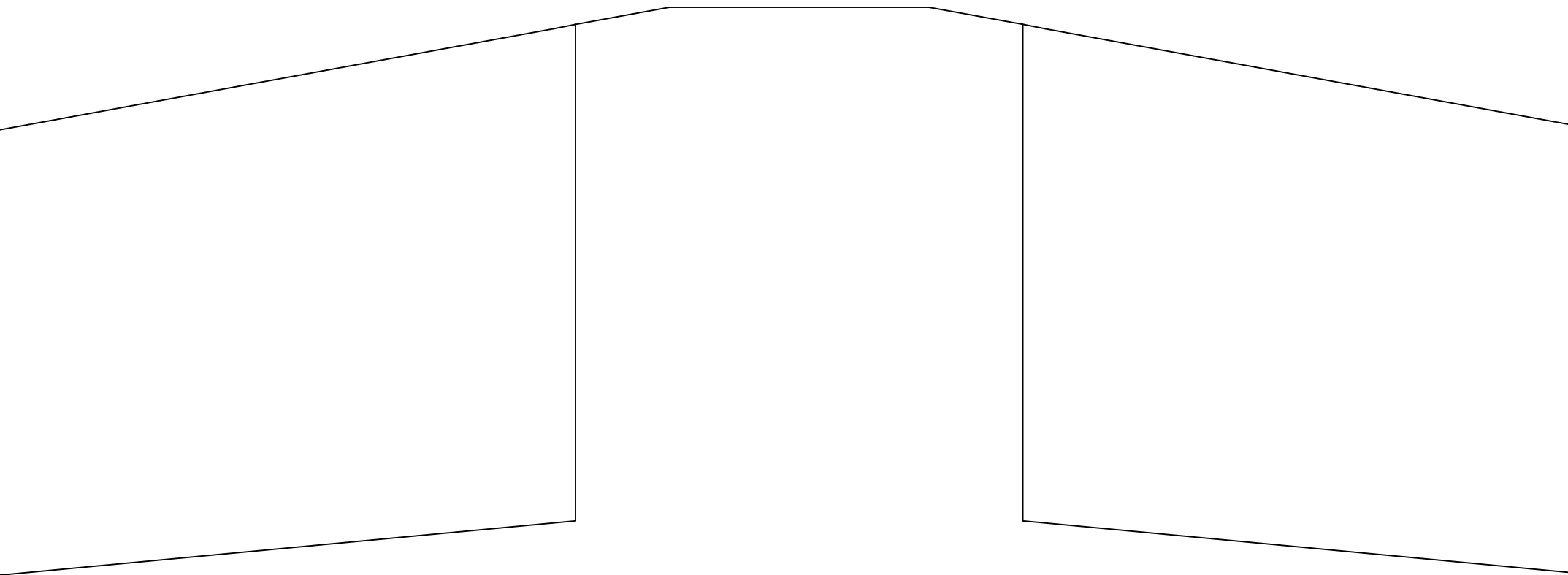

6mm foam

6mm foam

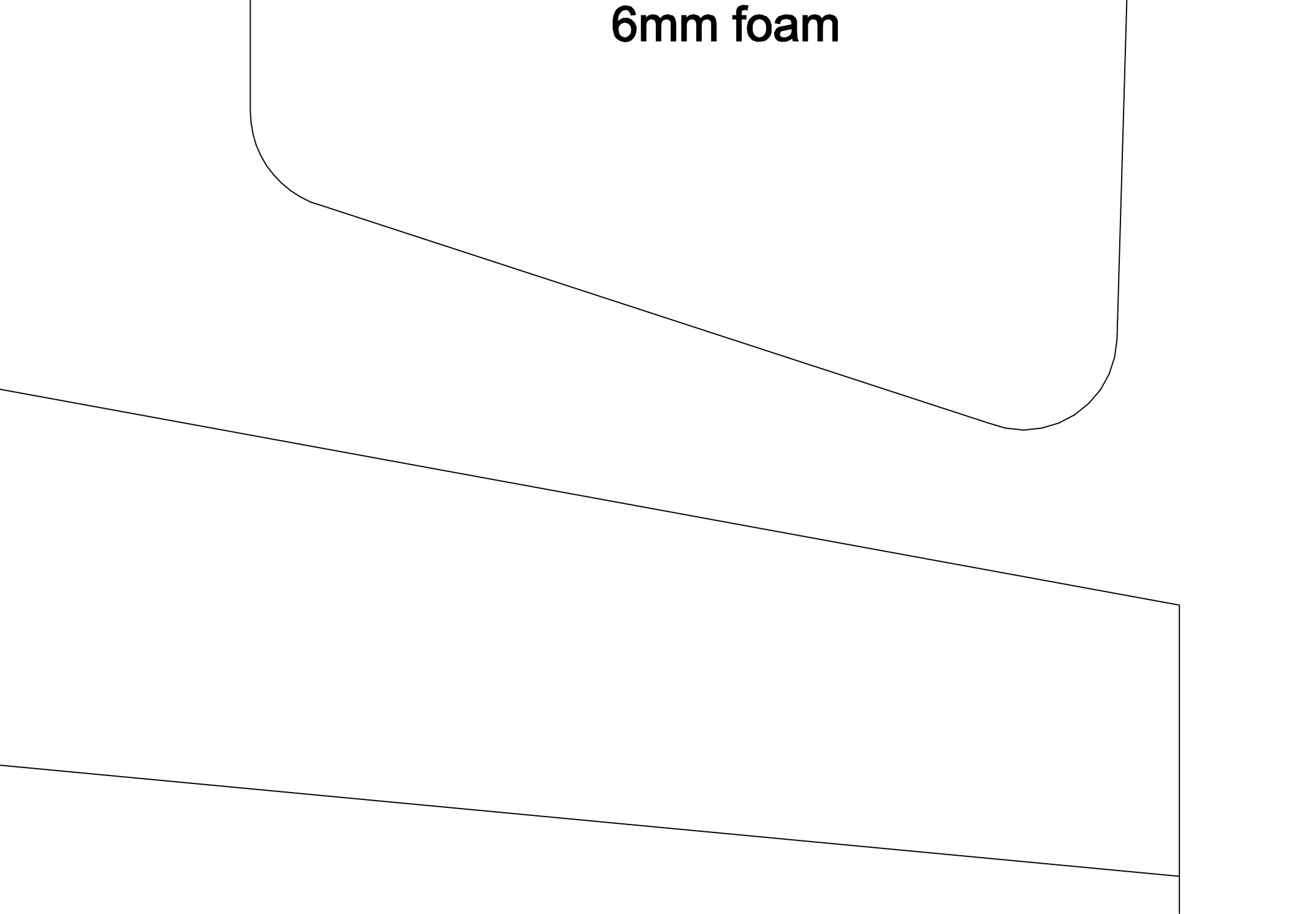

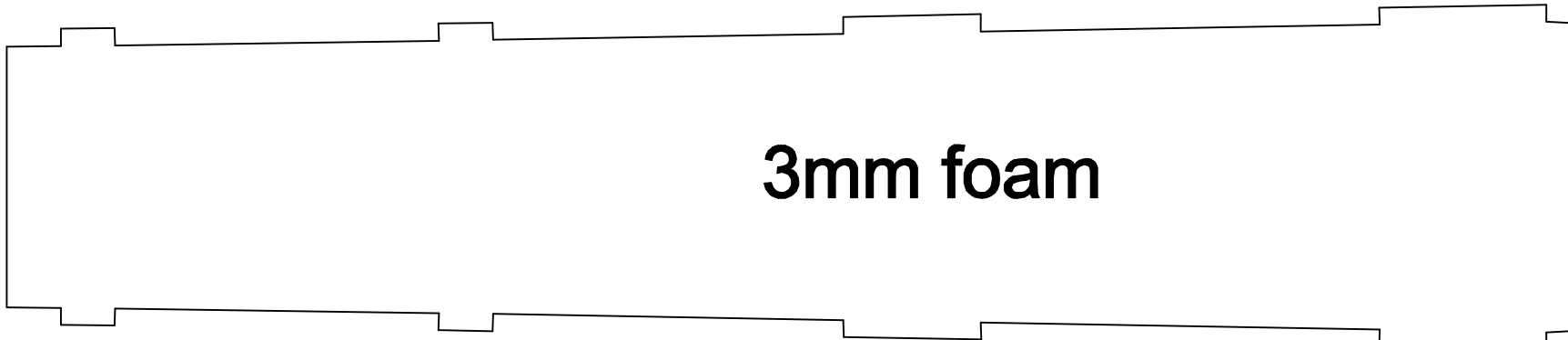
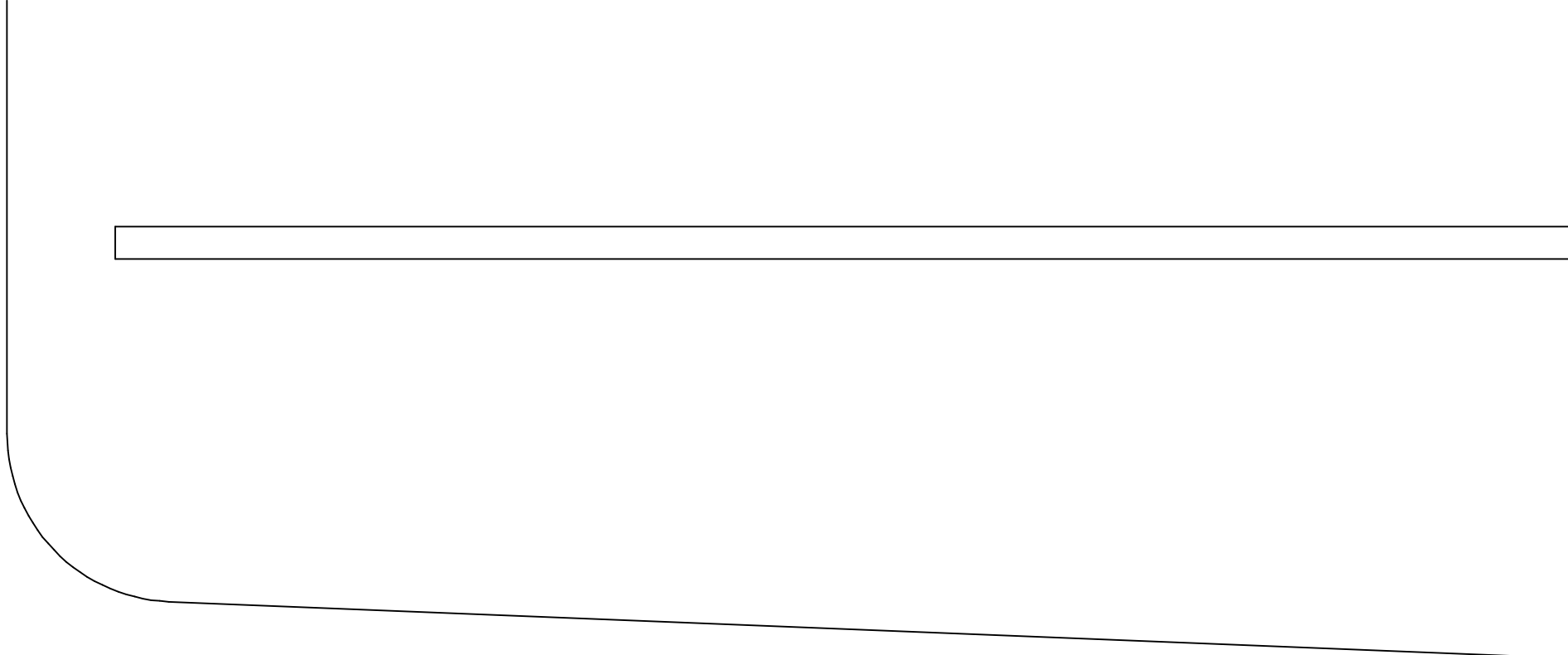
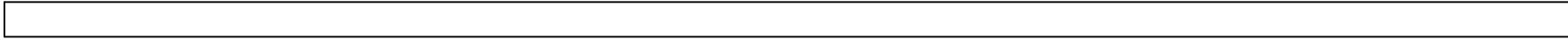

3mm foam

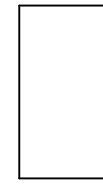

.210" x 29.5" Carbon tube for wing spar



Cooling vent

A technical drawing of a wing spar cross-section. The spar is a long, thin, tapered component with a central hole. The hole is wider at the ends and narrower in the middle. The drawing shows the outer profile and the inner hole. A label 'Cooling vent' is placed inside the hole, pointing to a specific feature.

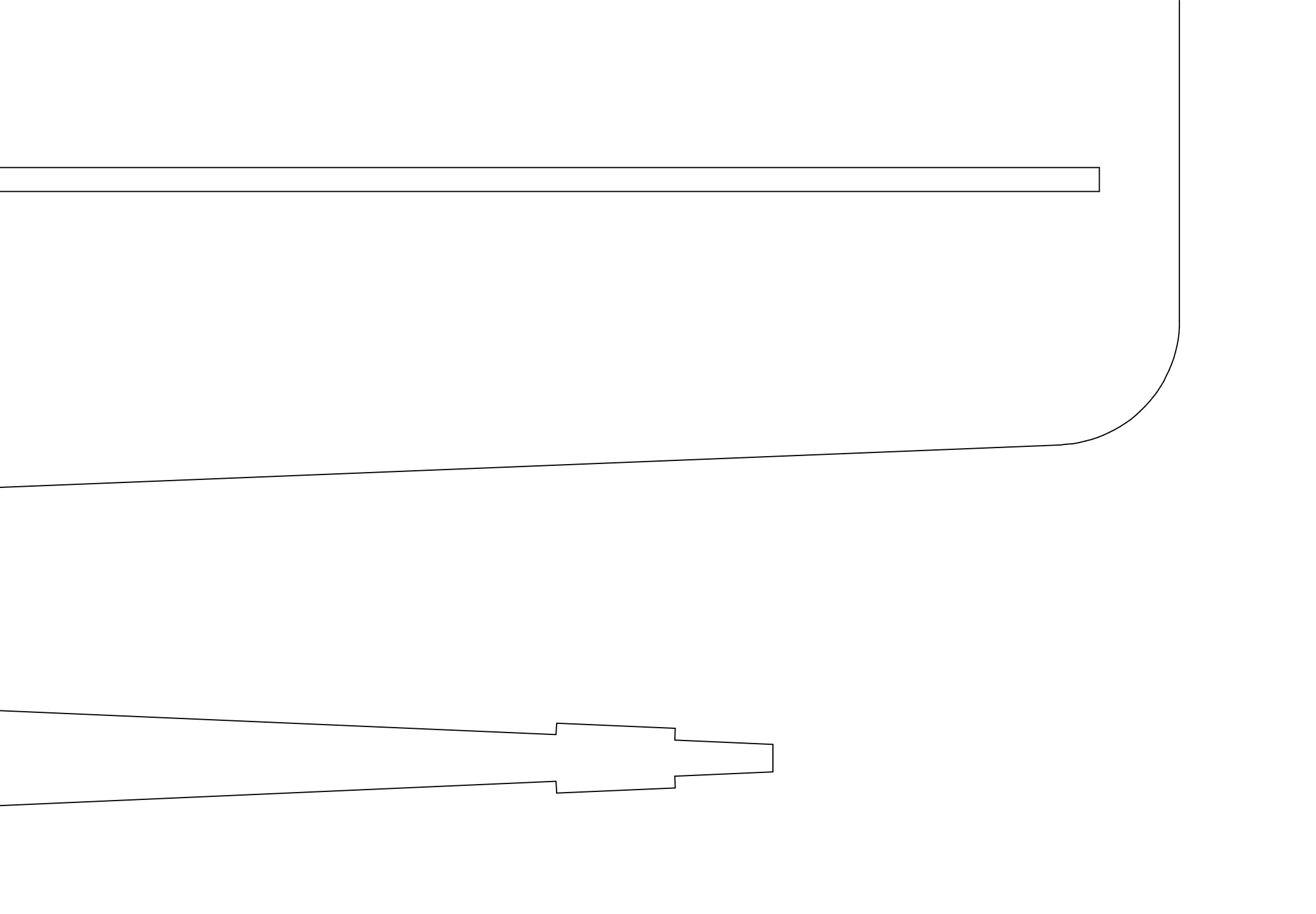

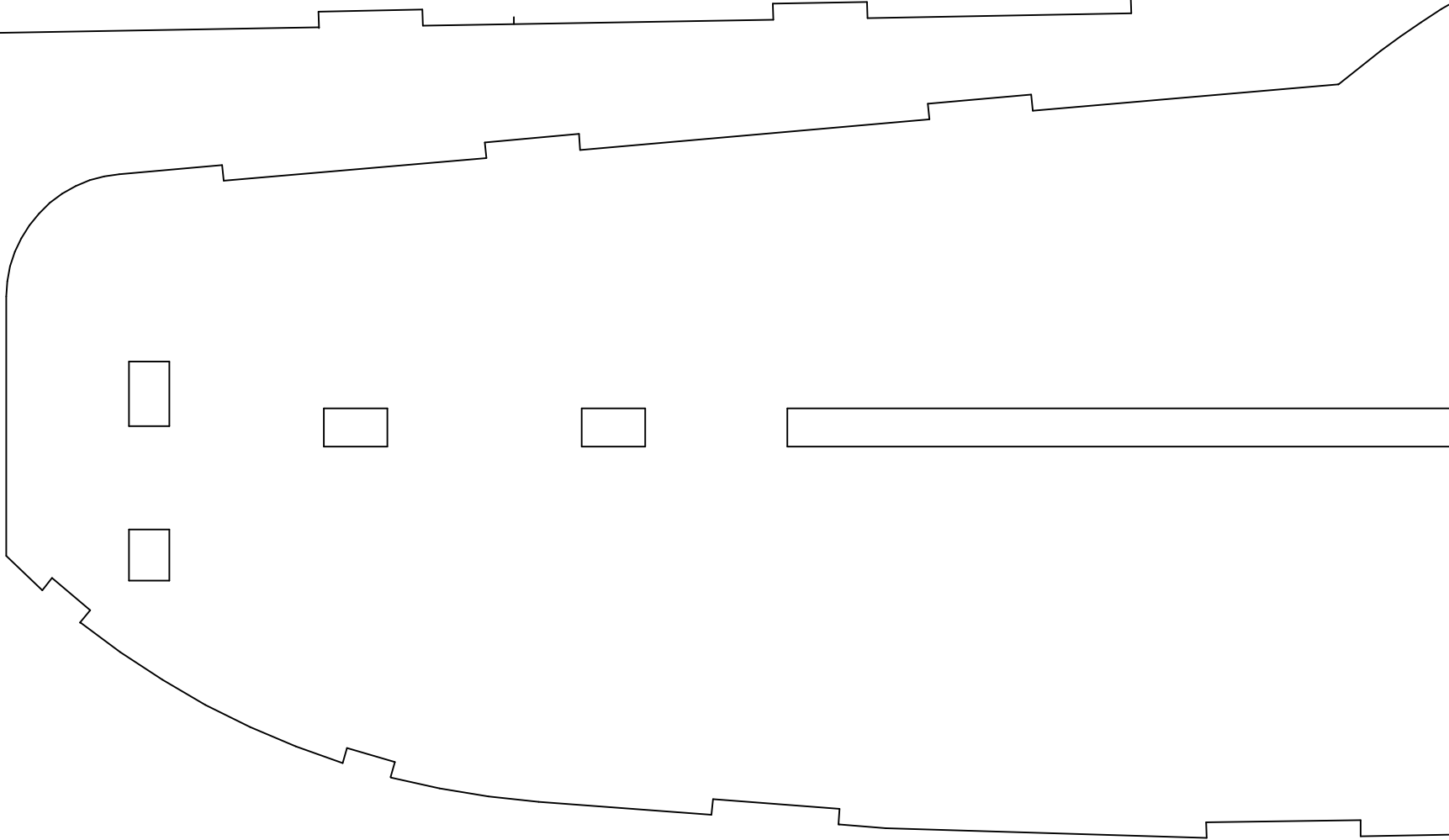
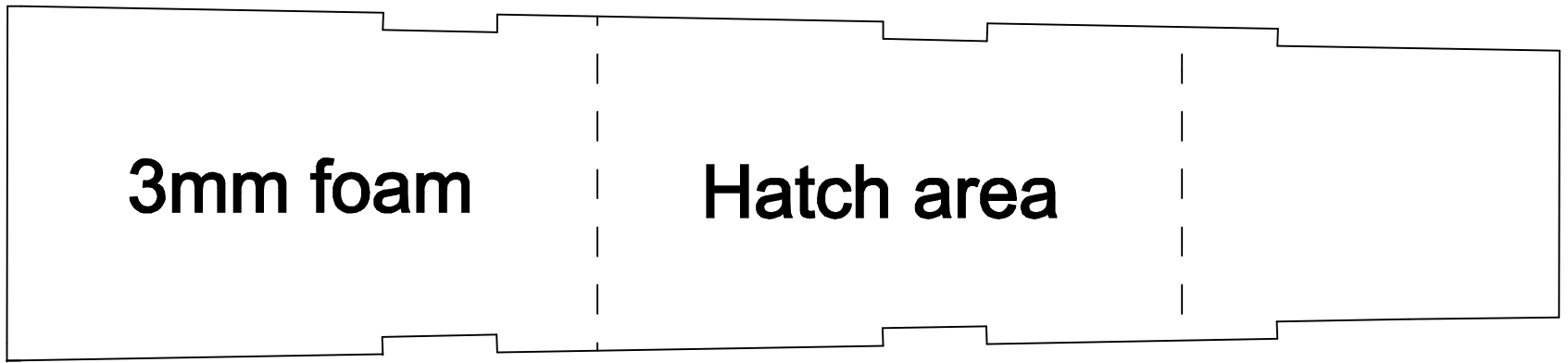

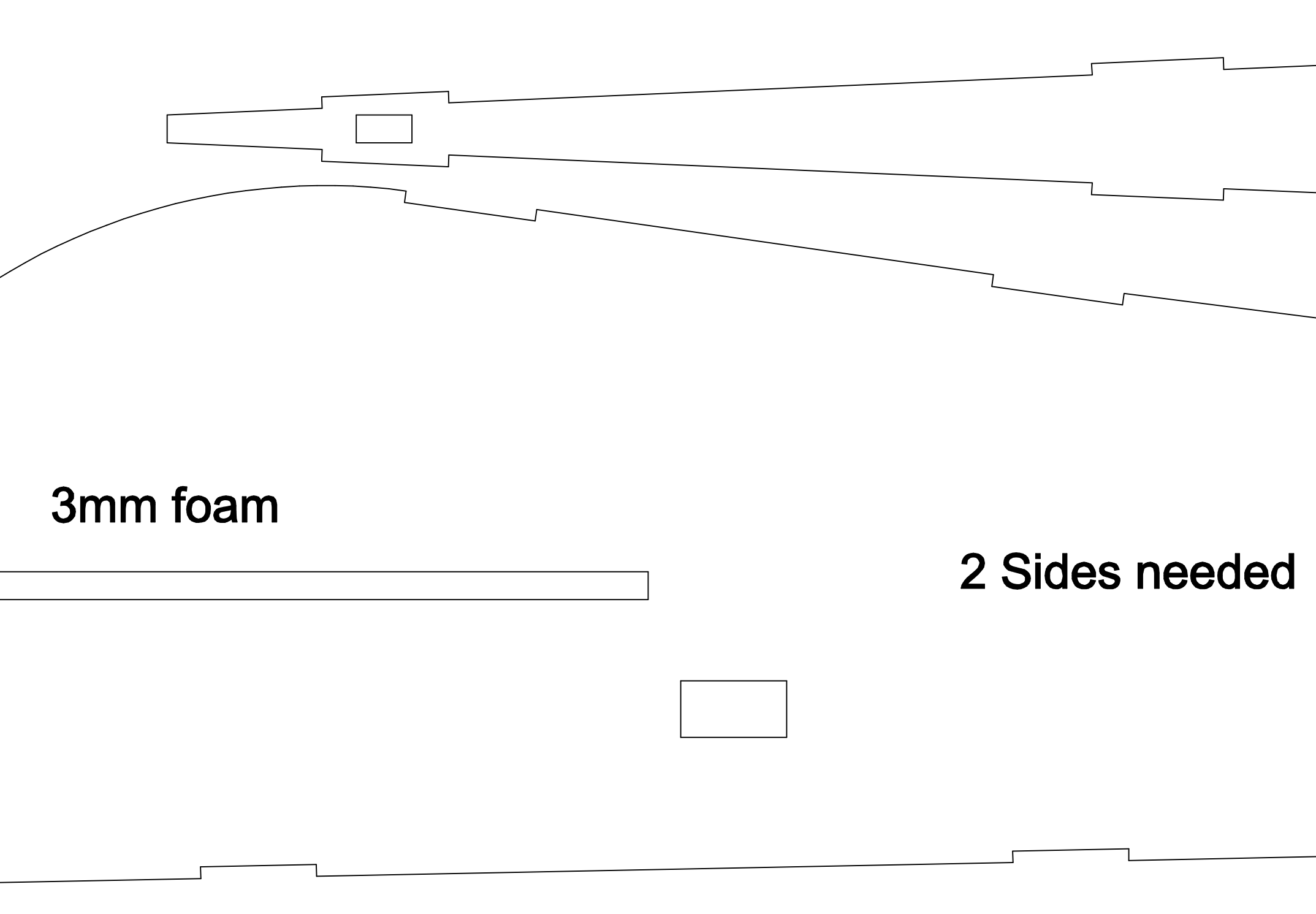

3mm foam

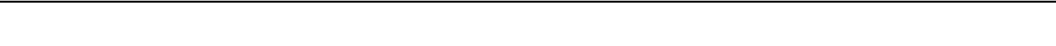

2 Sides needed





3mm foam

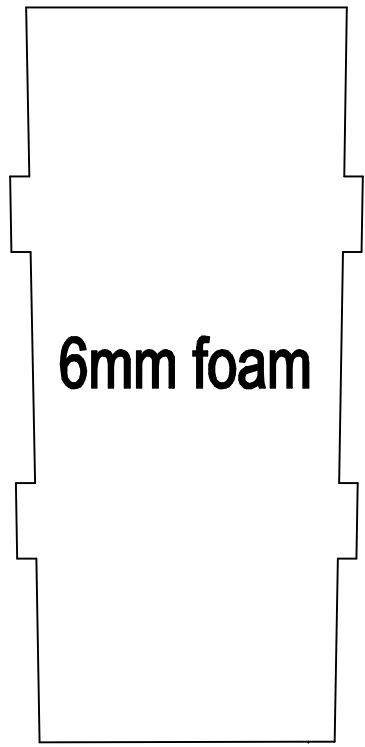
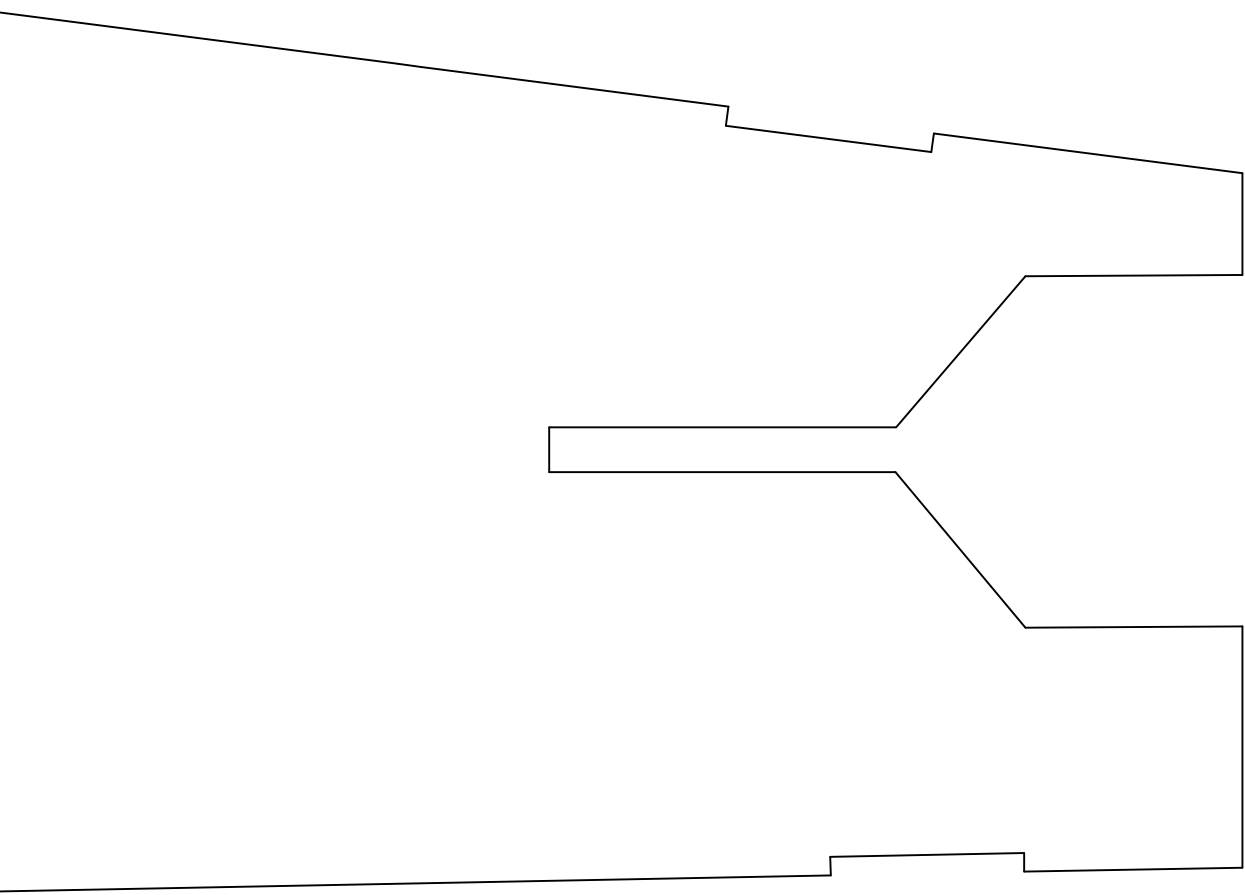

6mm foam